

4. TOOL HOLDERS

4.1 For external threads w/ quick change system: Holders for dies (DIN 223 / EN 22568)

For use on lathes, CNC machines or drill presses

Our new AKON die holders with quick change system enable problem-free and exact threading. Place the die in the threading attachment and get started.

Advantages

Fast exchange

The new AKON die holders consist of a basic holder and several threading attachments, which can be exchanged easily and quickly.

Easy to use

The basic holder is merely placed onto the lathe mandrel fitted in the tailstock. The holders are secured against torsion with parallel keys.

Thread cutting through straight alignment on a lathe

The holder is guided precisely on the lathe mandrel and therefore threads are cut perfectly and straight. No more poor finish or defective threads.

For CNC machines and drill presses

The threading attachments together with the matching holders can also be used on CNC machines or drill presses.

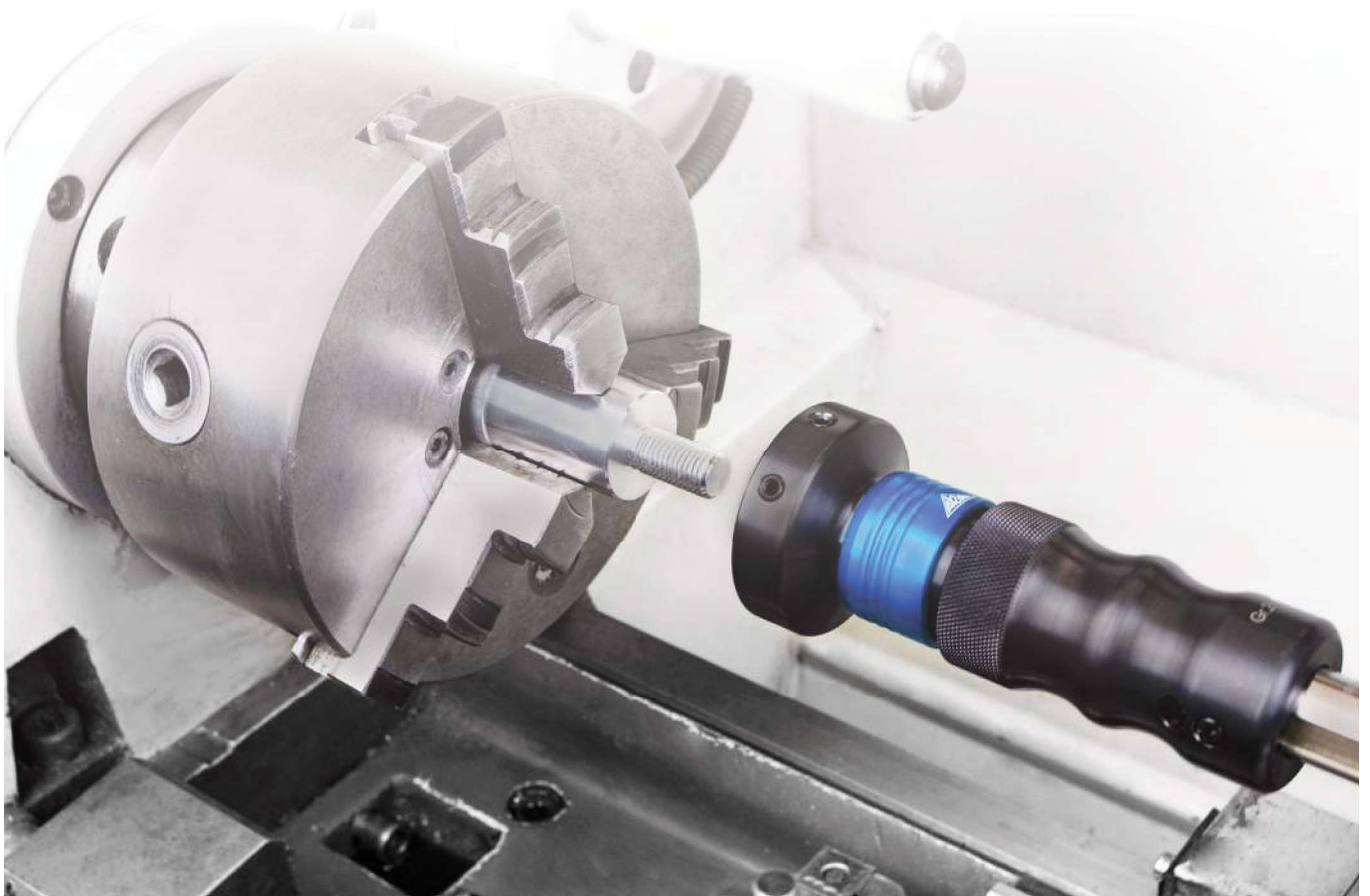

4. TOOL HOLDERS

4.1 For external threads w/ quick change system: Holders for dies (DIN 223 / EN 22568)

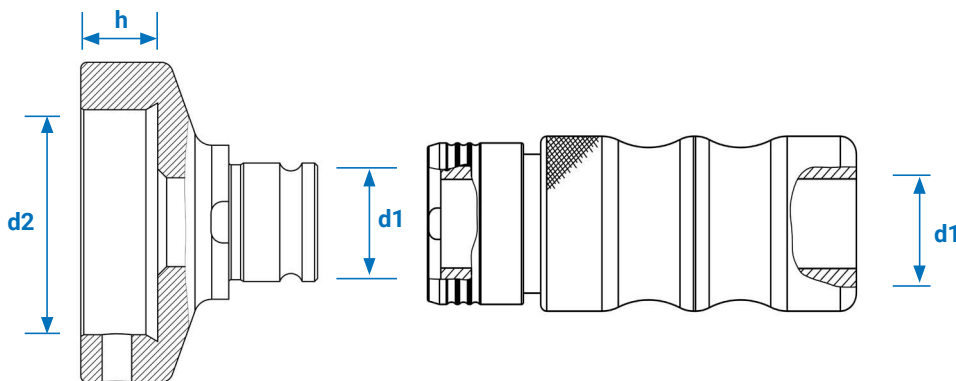

A lathe mandrel is to be ordered together with the basic holder.

Part No.	Size	For die OD and hight (mm)	Dimensions (mm)			Thread size to be cut		
			d1	d2	h	ISO metric coarse thread size - DIN 13	ISO metric fine thread size - DIN 13	Max. thread length (mm)
021000	2	Grundhalter	20					
022007	2	Aufsatz für 20 x 7/5		20	7	M3 - M6	M3 x 0.35 M6 x 0.75	70
022509	2	Aufsatz für 25 x 9		25	9	M7 - M9	M7 x 0.75 M9 x 1	80
023011	2	Aufsatz für 30 x 11		30	11	M10 - M11	M10 x 0.75 M11 x 1	
023814	2	Aufsatz für 38 x 14/10		38	14	M12 - M14	M12 x 1 M14 x 1.5	

~~Scope of supply: Shim rings are not included in the scope of supply.~~

The threads to be machined represent only a small selection. Please refer to your die catalog for additional dies which can be used with, to cut Whitworth threads, Whitworth pipe threads, etc.