

## 4. TOOL HOLDERS

### 4.2 For external threads w/o quick change system: Holders for dies (DIN 223 / EN 22568)

For lathes

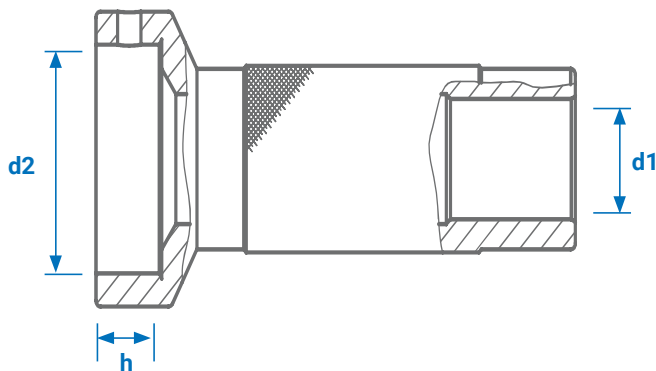

A lathe mandrel is to be ordered together with the die holder.

Part No.	Size	For die OD and hight (mm)	Dimensions (mm)			Thread size to be cut		
			d1	d2	h	ISO metric coarse thread size - DIN 13	ISO metric fine thread size - DIN 13	Max. thread length (mm)
101605	1	16 x 5	12	16	5	M1 - M2,6	M2 x 0.25 M2.6 x 0.35	60
102007	1	20 x 7/5	12	20	7	M3 - M6	M3 x 0.35 M6 x 0.75	70
304518	3	45 x 18/14	25	45	18	M16 - M20	M16 x 1 M20 x 2	80
305522	3	55 x 22/16	25	55	22	M22 - M24	M22 x 1 M26 x 1.5	70
306525	3	65 x 25/18	25	65	25	M27 - M36	M27 x 1.5 M36 x 2	

**Scope of supply:** Die holders include a hex key. Shim rings are not included in the scope of supply.

The threads to be machined represent only a small selection. Please refer to your die catalog for additional dies which can be used with, to cut Whitworth threads, Whitworth pipe threads, etc.

### Accessories for die holders - Shim rings

The shim ring is required for cutting fine threads. It is inserted into the holder together with the die.

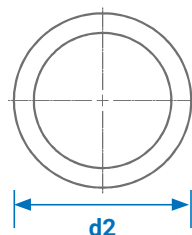

Part No.	Dimension d2 (mm)	For holder/ attachment part No.
012205	20	102007 & 022007
023810	38	023814
034514	45	304518
035516	55	305522
036518	65	306525